

Dear Customer,

Thank you for choosing this product. This kit only contains parts required to assemble the bridge as shown below in the component list. For the assembly you will need wire (approx. 6 metres) for the handrails (bore $d = 1.5\text{mm}$), wood planks to cover the walkway, paint and glue or solder. Two-part epoxy type glues can be used. Parts are designed to slot into each other, little taping necessary to make sure they are fitted properly. The kit contains the following components:

A: 2 pieces (cca. 1 m x 8 cm)

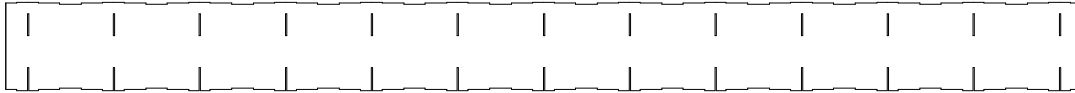

B: 2 pieces (cca. 1 m x 8 cm)

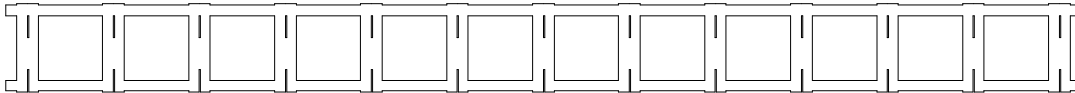

C: 1 piece (cca. 1 m x 6 cm)

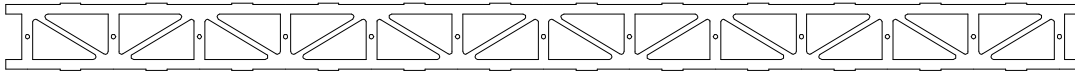

D: 1 piece (cca. 1 m x 6 cm)

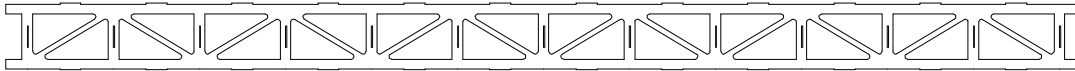

E: 2 pieces (cca. 1 m x 2 cm)

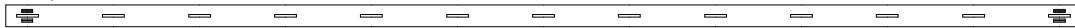

F: 2 pieces (cca. 1 m x 8 cm)

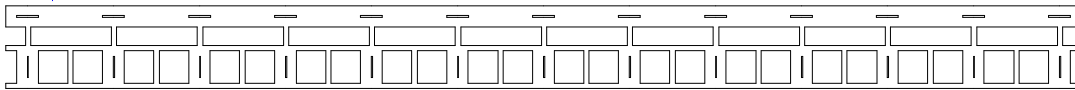

G: 13 pieces
(cca. 20 cm x 14 cm)

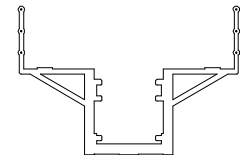

H: 16 pieces
(cca. 2 cm x 2 cm)

I: 4 pieces
(cca. 3 cm x 3 cm)

Part A: Web plate

Part B: Imitation of the lower and upper flange and the side of the stiffeners

Part C: Cross-bracing on the top of the bridge with holes to mount the rails

Part D: Cross-bracing on the bottom of the bridge with slots for the cross sections

Part E: Lower flange plate

Part F: Upper flange plate with support for the walkway

Part G: Cross sections containing the handrail posts, stiffener, support for walkway and lower reinforcing plate

Part H: Vertical parts for the leg

Part I: Horizontal part for the leg

The internal faces of the bridge (internal of the girder) are difficult to paint with regular spray. It is advisable to paint these surfaces before assembly. The paint might get damages during assembly which can be corrected once the bridge is fully assembled.

We hope that you enjoy our bridge and it will serve you garden railway for many years to come.

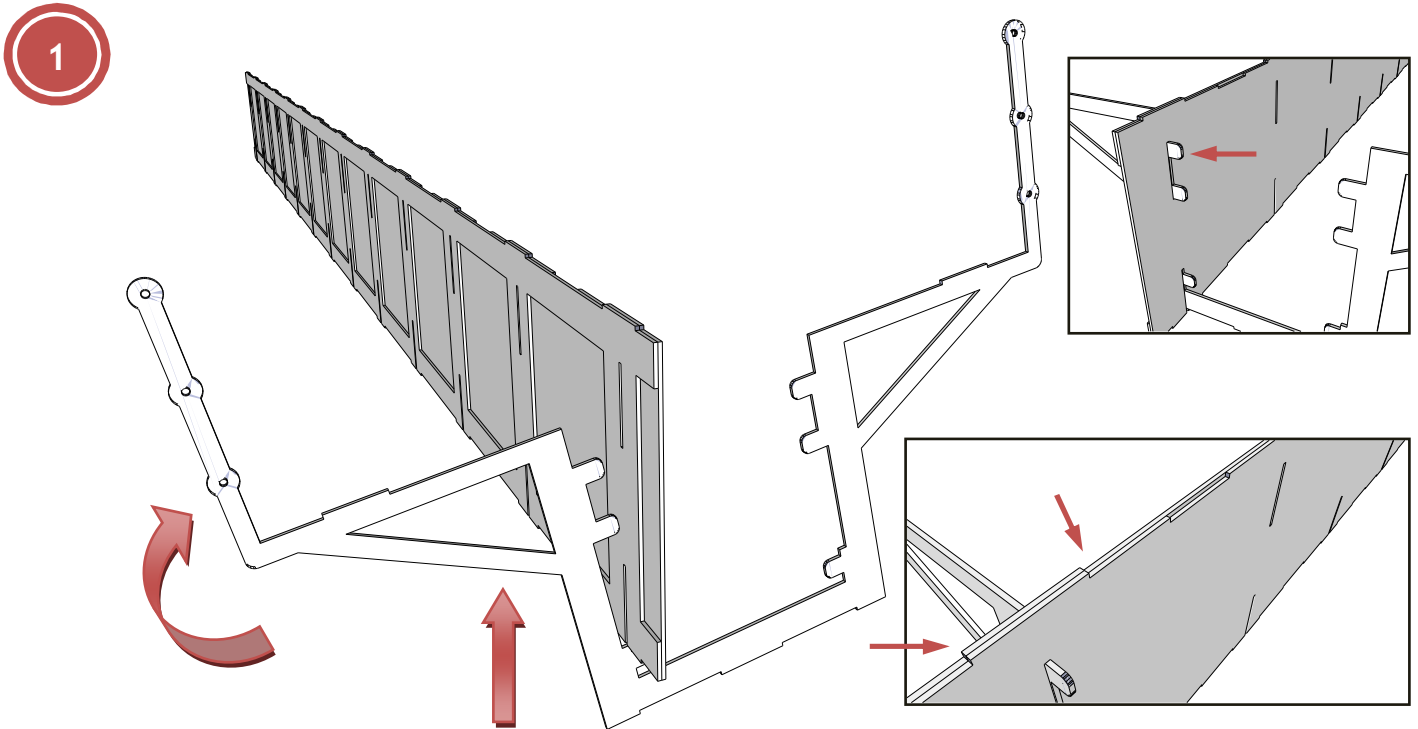

Align Part A and Part B with holes in the middle and at the bottom. Slide the cross section in from below rotated as shown above then turn upright. The bits on the cross section slides into the holes (top right diagram). Bits of Part A and Part B should align (lower right diagram).

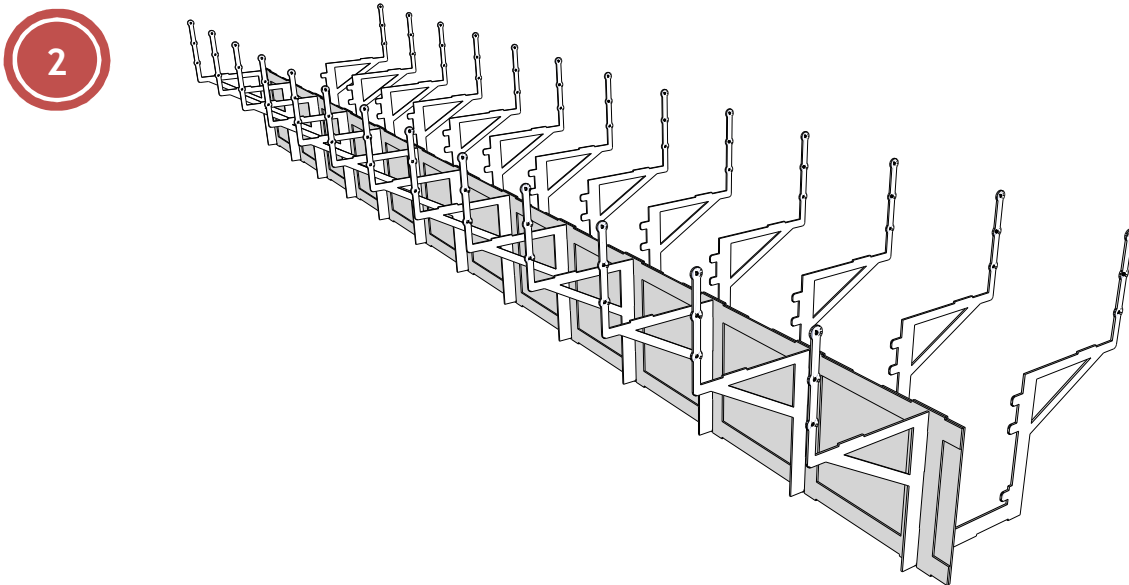

Complete cross section assembly with the rest of Part C items similarly to step 1.

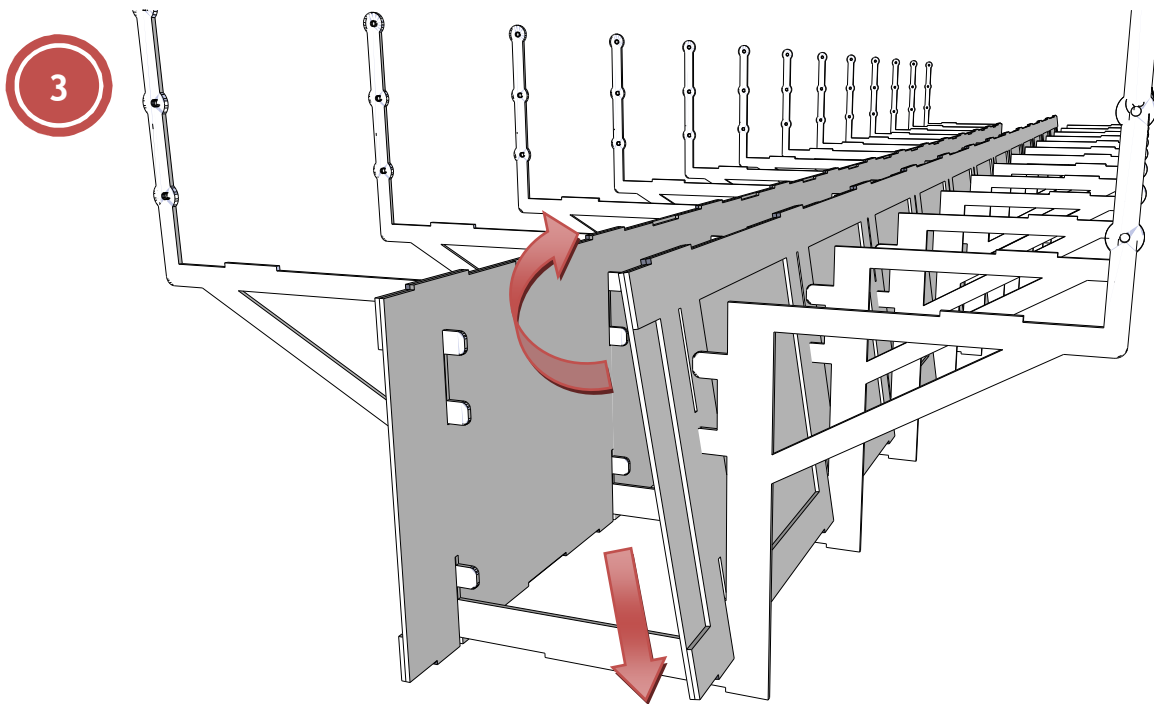

Take the remaining Part A and Part B items and align them similarly as in step 1. Slot them into the cross sections through the bottom slots in an angle. Turn them upright.

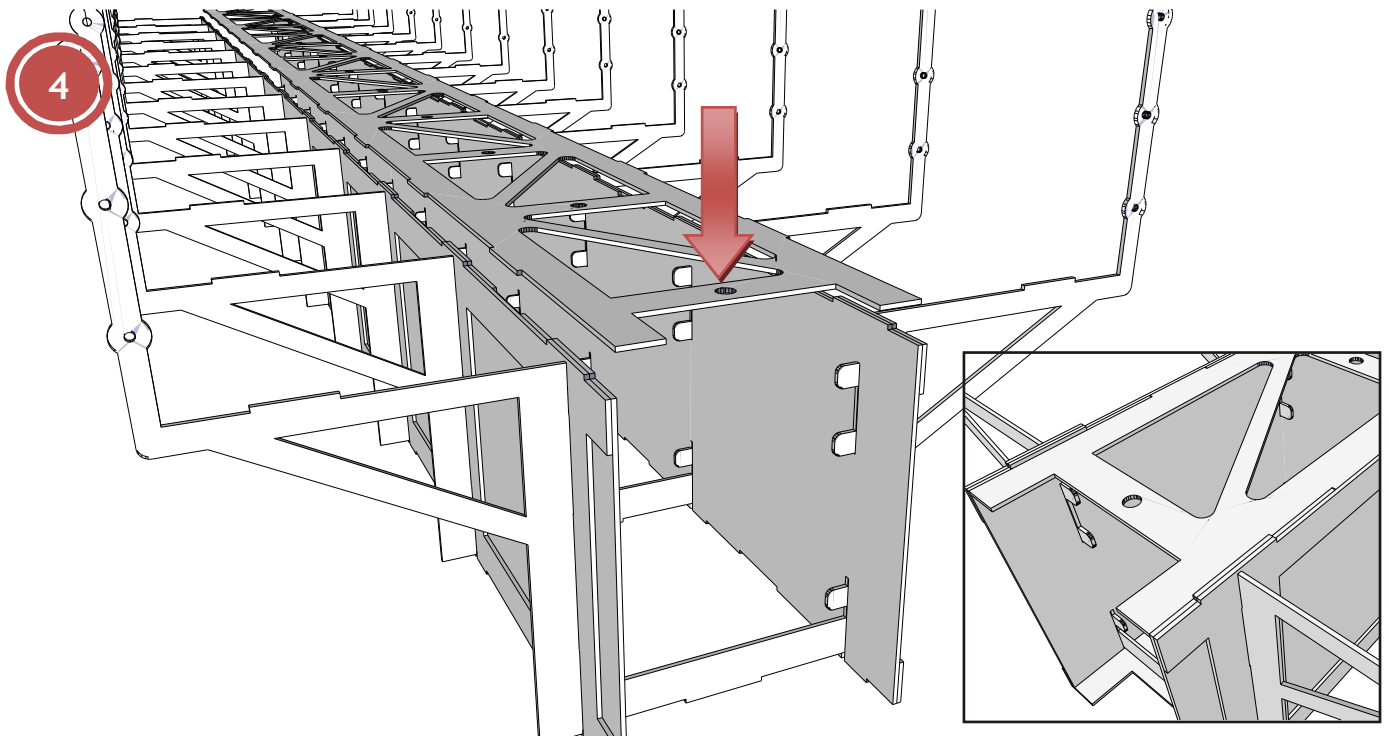

Take Part C and place it between the sides. Bits on Part C slide into the groves on Part A. Cross-bracing should fit tightly between the sides without any adhesive. End of the cross-bracing should align with the end of the sides. Top of the sides (Part A and B) should be the same height as the top of the cross section. Both have 1 mm high bits.

5

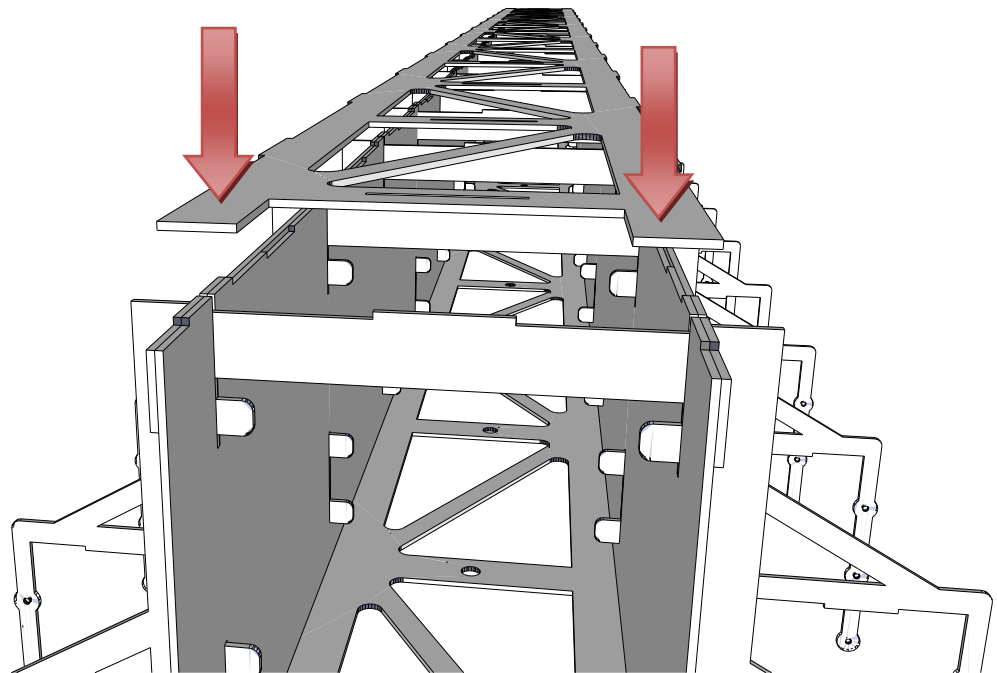

Turn the bridge over and place Part D between the sides similarly to the previous step. Again the cross-bracing should be firmly locked in place. If glue is used apply some adhesive on the bits on Part G.

6

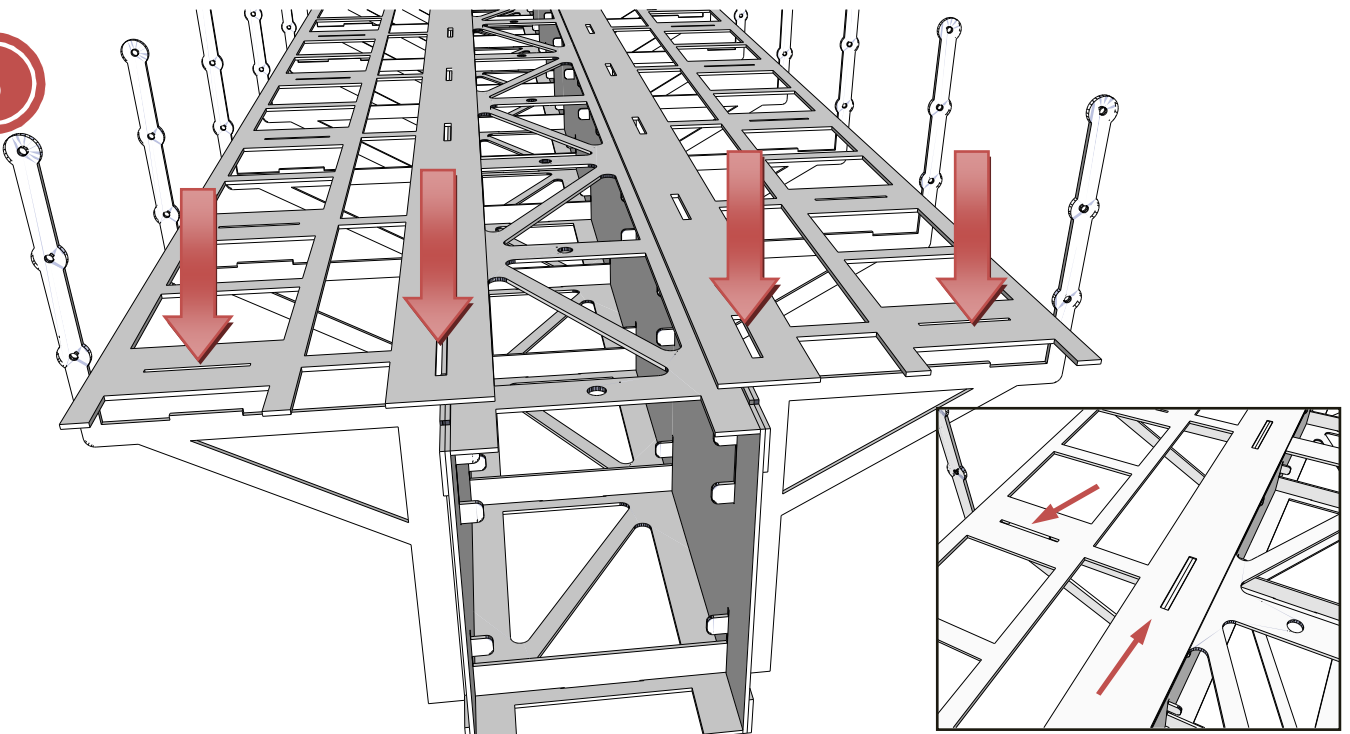

Take Part F and place it on either side of the bridge to cover the sides and the walkway. Bits on Parts A, B and G slot into the holes of Part F (lower right diagram). If glue is used apply adhesive on top of the cross-bracing and on the top of the sides, and on the locking bits of Part G. Steps 6, 7 and 8 can be done in any order.

7

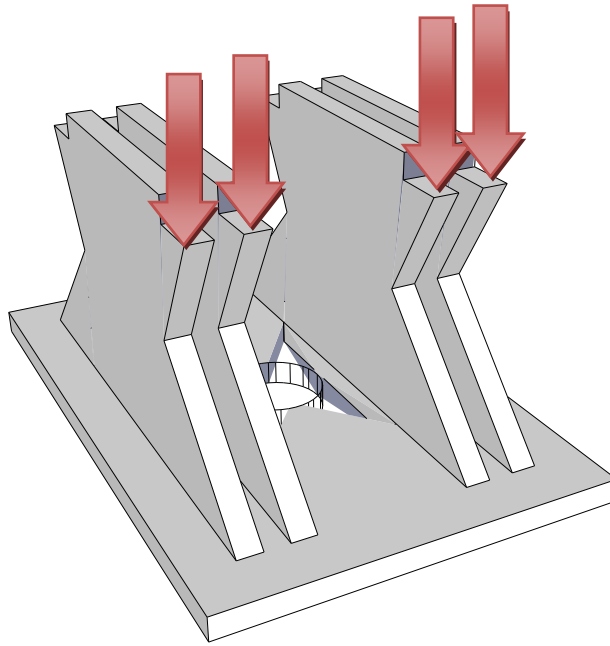

Complete the leg assembly as shown above. 4 pieces of Part H slot into Part I. Assemble all four legs.

8

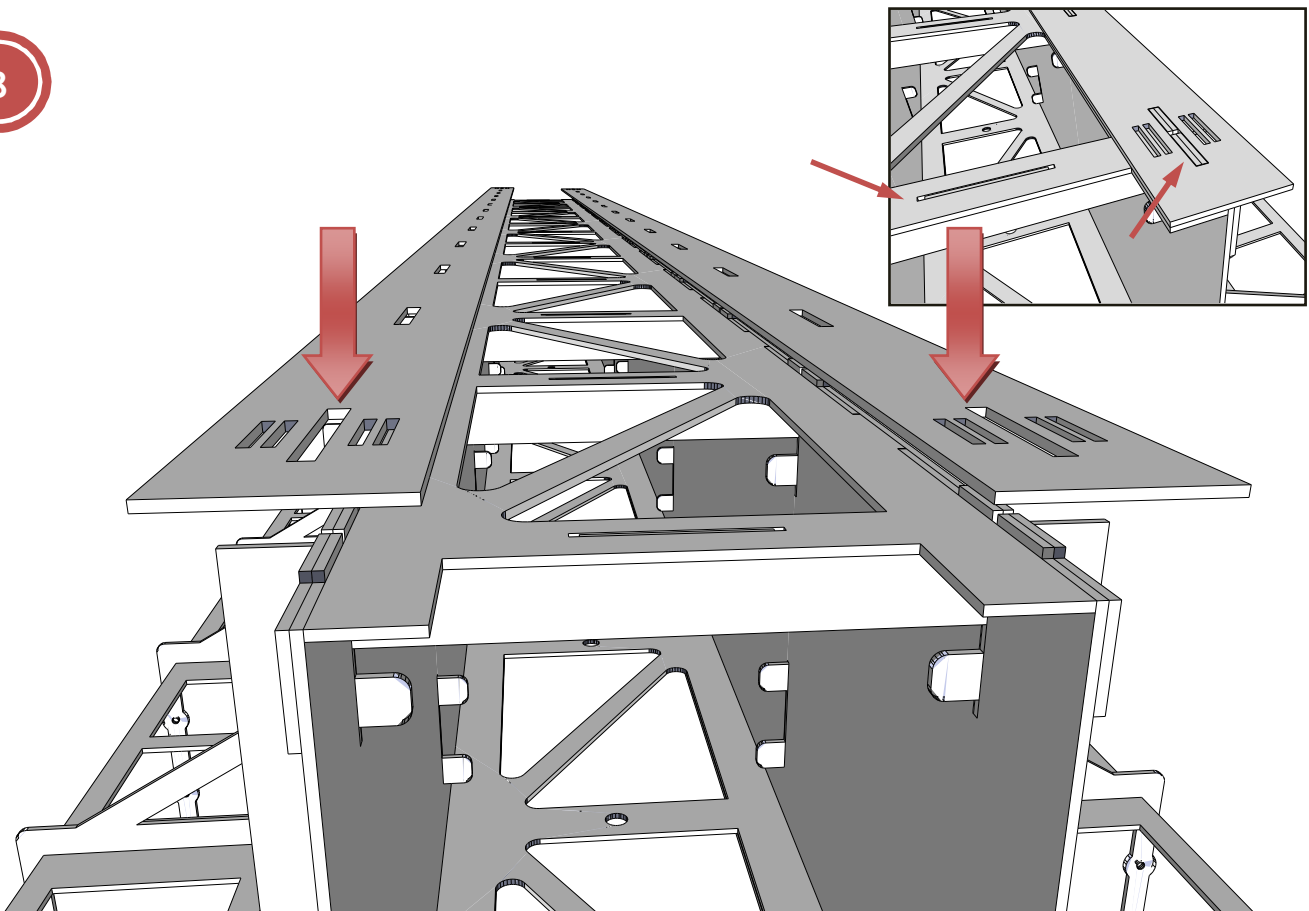

Fix the two bottom flanges (Part E) at the bottom of the bridge. If glued apply adhesive on the cross braces and on top of the sides. Bits of Part A and B should fit into the holes of Part E (see small diagram). When applying glue ensure that it does not block the holes for the legs (see next step).

9

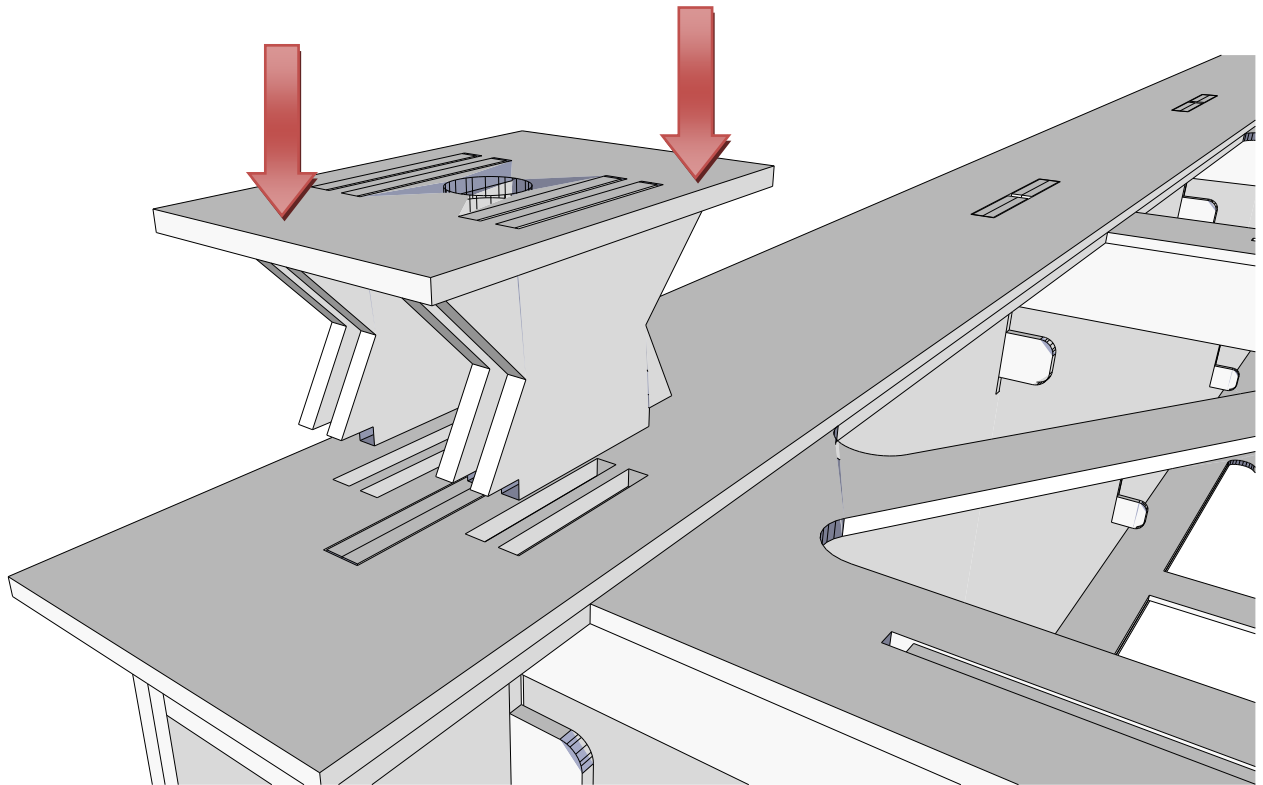

Mount the leg assembly on the bridge by slotting into the holes of Part E.

10

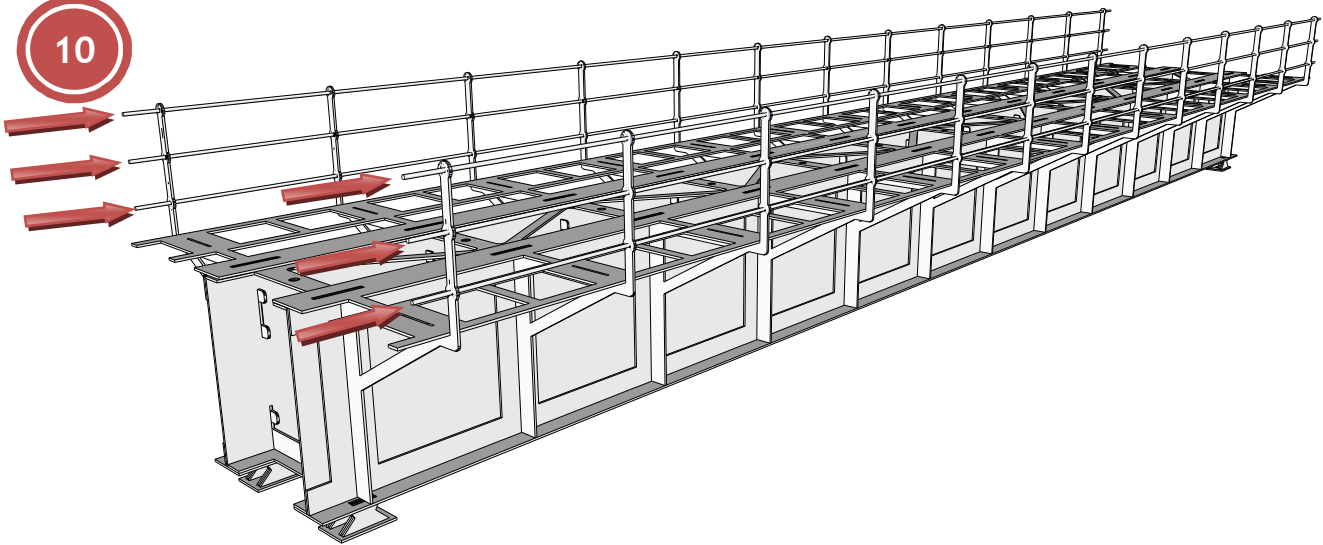

The main assembly is complete. Use steel / brass wire for the handrails. Internal diameter of the holes is 1.5 mm. Use treated / preserved wood planks for the sidewalk decking.